

KABELSCHLEPP

Innovative solutions
for the crane industry



Costs down – service life up

Cable carrier systems for cranes

TSUBAKI KABELSCHLEPP develops customized solutions for cable carrier systems in cranes. Our decades of experience across various industries with diverse demands on our cable carrier systems has led to new custom and application-specific solutions for our customers. Our specialists will support you in the planning and design stage, making on-site visits and collaborating with you to create a solution that is specific to your needs.

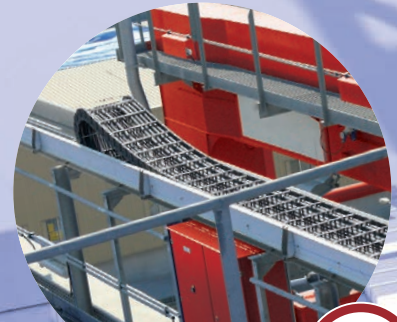

Rubber Tire Gantry (RTG)



Rail Mounted Gantry (RMG)



Ship To Shore Container Cranes (STS)



Automated Stacking
Cranes (ASC)

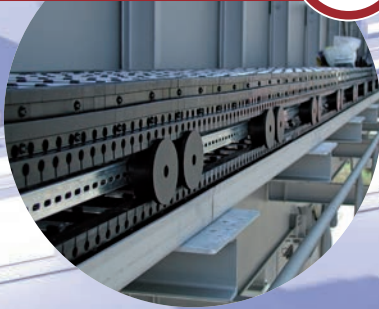

Reach stacker



Spreader



TSUBAKI KABELSCHLEPP

Your partner for crane applications

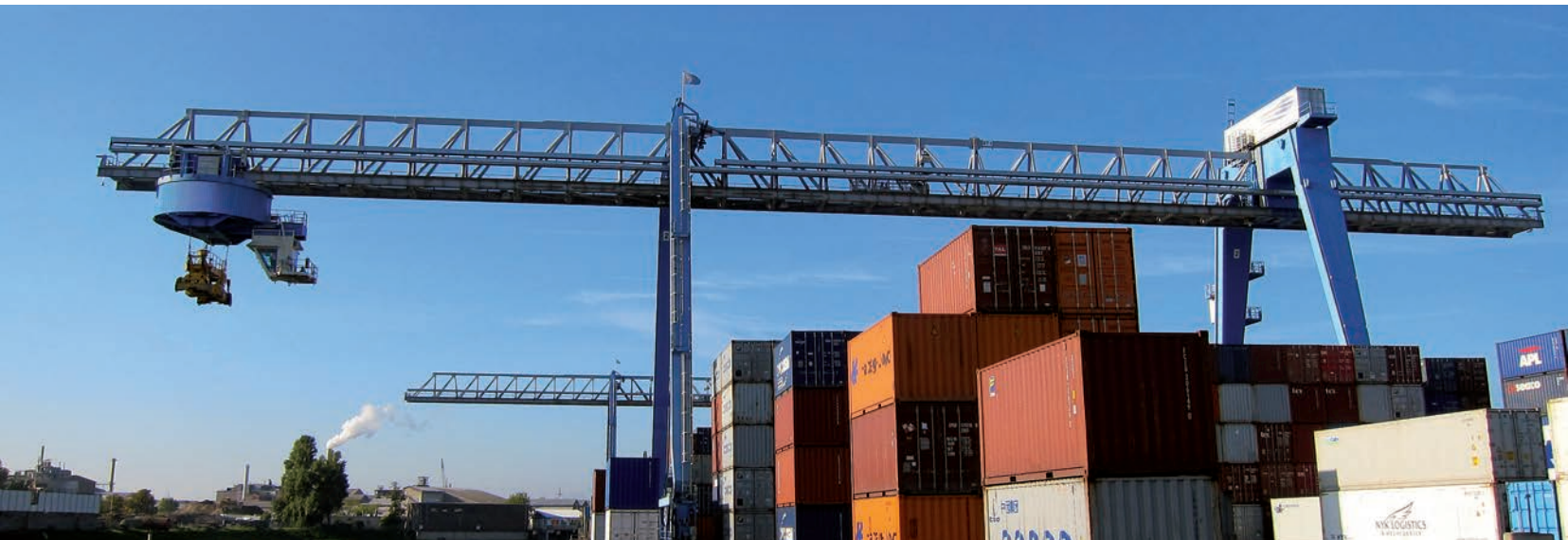

Engineering by TSUBAKI KABELSCHLEPP

TSUBAKI KABELSCHLEPP is a total solution provider. Our half-century of experience and thousands of installed applications worldwide make us a valued partner that you can rely on for your applications. Our specialists will support you from planning through execution creating a design specific to your needs.

In order to achieve an optimal upgrade to the respective equipment, our experts will coordinate the appropriate components for your application. As required, we use standard components or we can custom configure our systems to adapt them to the existing structures.

- site measuring for best engineering and assembly planning
- application specific assembly and maintenance manuals
- CAD documentation of the installation in 2D and 3D formats for your records

Benefits of cable & hose carriers for cranes

- cost-effective (compared to festoon systems) due to shorter cable lengths – no inefficient hanging loops are required
- extended cable service life – the cables are only bent in a defined bend radius and do not have to absorb any pulling forces
- very long travel lengths possible
- weatherproofed for offshore/onshore conditions
- low maintenance
- secure protection of cables and hoses even in high wind conditions, no mechanical loads on the crane
- secure data transfer with LWL cables
- no additional drives and control units necessary
- all power, control, data, pneumatic, water or hydraulic cables in one system



KABELSCHLEPP specializes in cable carriers for all types and sizes of cranes and has been a pioneer in dynamic cable and hose carrier systems ever since the invention of the original cable carrier that was patented by KABELSCHLEPP in 1954.

As modern crane systems demand increasingly higher cycle rates and travel speeds, they need cable management solutions that can hold up to the new requirements. To meet these demands, today's port cranes and lifting devices require lightweight polymer cable carriers that offer high speed, high acceleration and high durability.

Cable carrier systems made of polymer can help you to adapt your systems to meet these new demands. TSUBAKI KABELSCHLEPP even has solutions for extremely long travel applications that require high travel speeds and accelerations.

Since 1954, KABELSCHLEPP cable carriers have proven to provide high reliability, high quality and cost-effective cable routing solutions. And continued innovation and advancements in technology will continue to allow TSUBAKI KABELSCHLEPP to create solutions to meet the challenging needs of the marketplace.

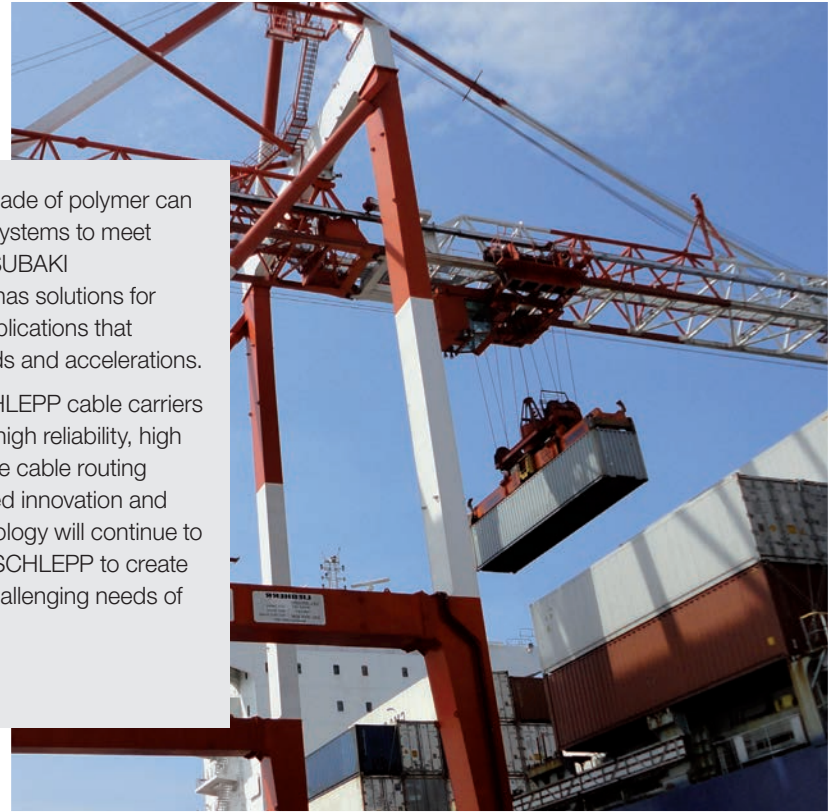

TOTALTRAX Complete Systems From planning to the final complete system

Use our know-how. Working jointly with you, our experienced specialists can provide pre-sale support, including planning and design services through after sales service and support.

One order, one contact person, components optimally matched to each other, including the cable and hose carrier, the electrical cables, the hydraulic and pneumatic hoses and the connectors.

You'll receive the complete system in one delivery, with guarantee certificate if desired – in short: TOTALTRAX.

Reduce your storage costs for cable and hose carriers, cables and connectors with TOTALTRAX.

We supply all components Just-In-Time to your production facility or directly to the installation site.



Outdoor testing facility

Proven quality – tested under real conditions



TSUBAKI KABELSCHLEPP stands for high quality and safe solutions. To ensure the highest standards we have an outdoor testing facility with real conditions. Gliding and rolling systems with travel lengths of more than 100 meters as well as high speed applications are being tested by our experts under harsh conditions.

Testing facility for all cable carrier types

- independent cable carrier systems beside each other
- gliding and rolling systems applicable
- travel lengths of more than 100 meters
- overtensioning protection system
- high speed (5 m/s) tests

Outdoor conditions

- exposed to harsh winter
- direct solar radiation
- heavy rainfalls

Material variety

Your application determines the material

EX



For Ex-protection applications, we offer customized solutions made from solid plastic, hybrid or steel cable carriers, which meet the requirements of the standard (with $< 10^5 \Omega$).

ESD



Our proven ESD cable carriers based on nano-technology with carbon tubes easily meet the requirements of the ESD standard (with $< 10^9 \Omega$) in terms of conductivity and resistance.



Flame Retardant

We offer special materials including V0 versions for operating areas having a risk of fire. All materials listed by UL94. Additional special solutions on request.

Low Temperature



Suited for usage in low temperature areas such as cold stores, etc., up to around $-40 \text{ }^\circ\text{C}$.

High Temperature

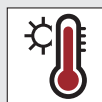

High temperature material 1: Suited for a (dimensionally stable) long-term temperature range for 2,500 hrs. up to $190 \text{ }^\circ\text{C}$ and for 10,000 hrs. up to $160 \text{ }^\circ\text{C}$.
High temperature material 2: Suited for transient surface contact temperatures of up to $800 \text{ }^\circ\text{C}$.



Video: Testing facility “in action”

Take a look at our testing facility “in action”. Gliding and rolling systems with travel length of more than 100 meters are tested under real conditions.



Information also on your Smartphone!
(QR READER app is a free of charge download)
kabelschlepp.de/testing-facility

Roller Supported Chain (RSC): High performance – low maintenance costs for all your relevant travel lengths

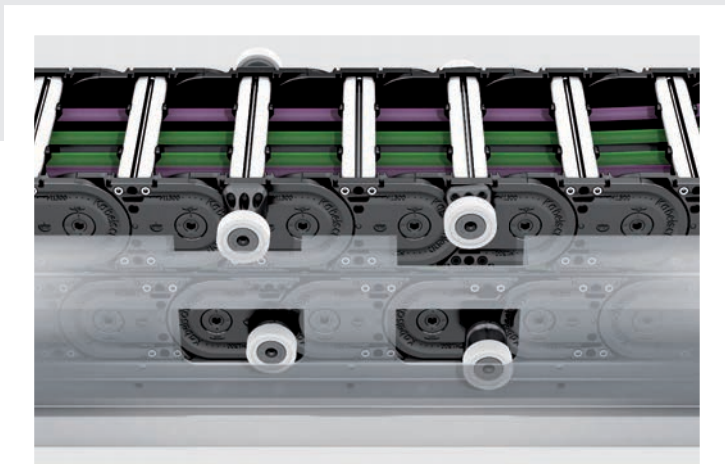

Less push/pull forces compared to gliding arrangements due to rollers

Rolling instead of gliding – the proven principle for less friction

Wherever it is impossible to install a gliding solution due to very long travel lengths or high friction, the Roller Supported Chain (RSC) is a safe and reliable solution. With the RSC, the upper trough does not glide on the bottom trough, as it runs on rollers. The rollers are mounted on ball bearings at the side of the carrier and allow very long travel lengths requiring substantially less driving power. The tension and thrust is 90 % less in comparison to gliding arrangements.

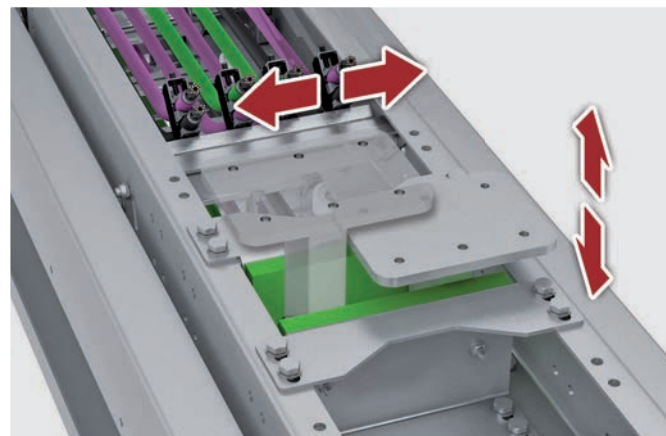

Floating tow arm carriage for self-adjusting variable connection

Minimized costs and maintenance time

In case of maintenance only the wear part roller can be replaced individually. A time-consuming and cost-intensive replacement of the entire cable carrier is no longer necessary. The rollers are easily accessible through cutouts in the channel and modular side panels. This saves time during maintenance and service.

Quiet and low-vibration operation

The rollers run on the guide rail and do not contact other rollers. Ball bearings and a polyurethane roller surface additionally contribute to quiet and smooth operation.

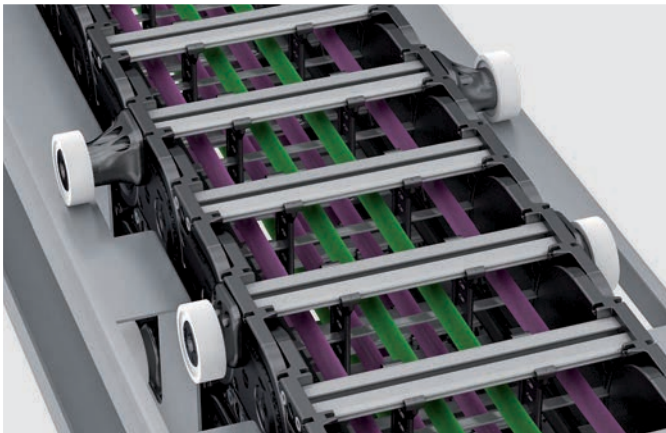
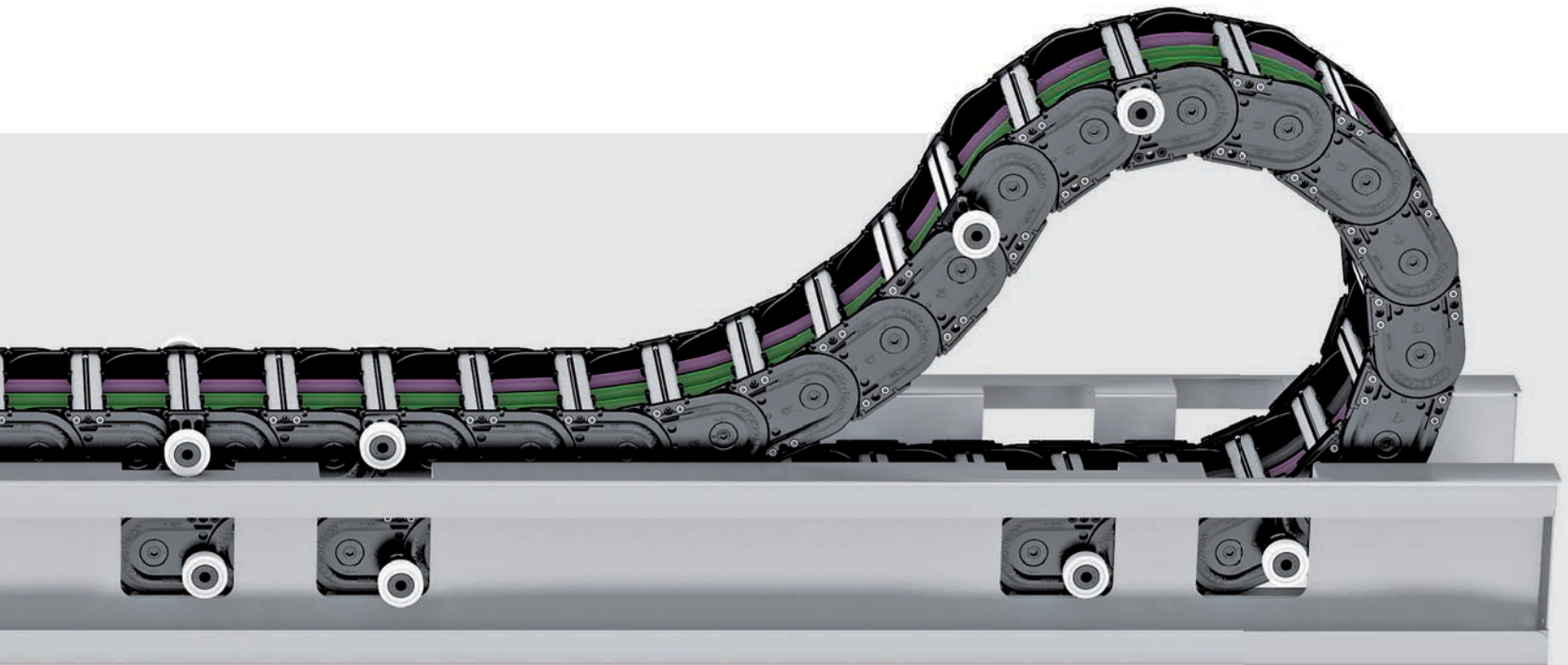

Easy maintenance – rollers can be replaced without replacing chain band



Integrated strain relief elements for safe cable fixing in the connection area

Roller Supported Chain (RSC)

- suitable for all your relevant travel lengths
- 90 % less tension and thrust compared to a gliding arrangement, thus requiring substantially less driving power
- low-noise and low-vibration operation
- less space required and cost-optimised with a shorter loop overhang – minimum turnaround length
- no impacting of the rollers against one another
- long service life – low maintenance
- minimum stress on the cable and hose carrier and cables

- less push/pull forces
- high travel speed and acceleration
- substantial additional capacity possible
- use of proven standard cable carriers
- the cable carrier cannot rise
- variable profile lengths, adjusted to your connection points

M Series

Proven cable carriers for long travel lengths, high speeds and high accelerations

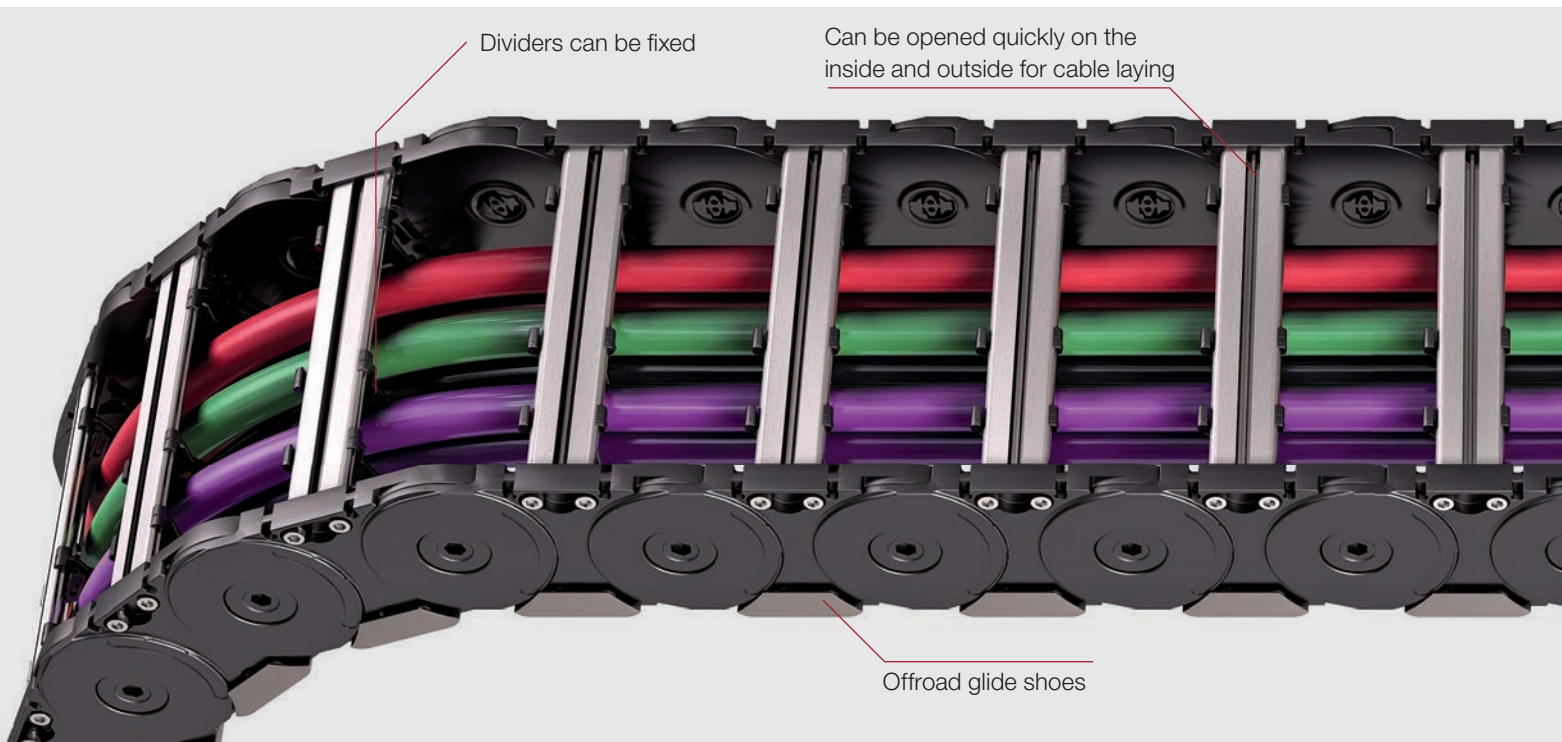

Multivariable system – fits to any application

Multivariable cable carriers with extensive accessories and stay variants for extreme long travel lengths.

- seawater resistant aluminum stays; bolted 4 times for high stability and extreme loads
- aluminum stays with custom widths available in 1 mm width increments
- extremely long service life in long travel applications due to replaceable glide shoes
- can be opened easily and quickly on both sides for cable laying
- enclosed stroke system protects against dirt/contamination
- large selection of divider systems for separating the cables and hoses

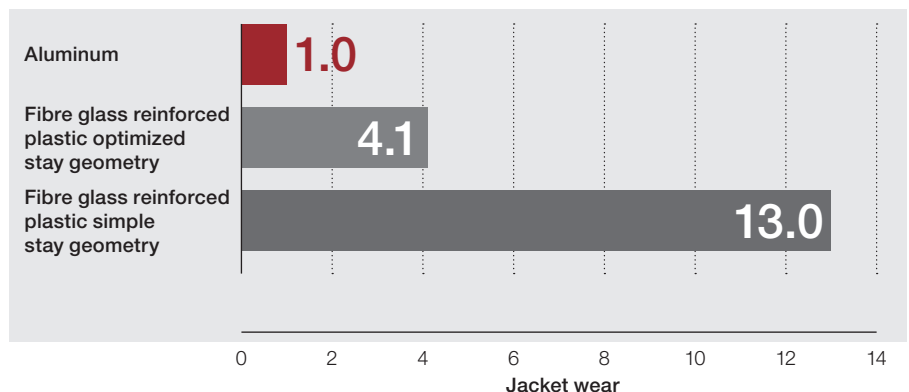
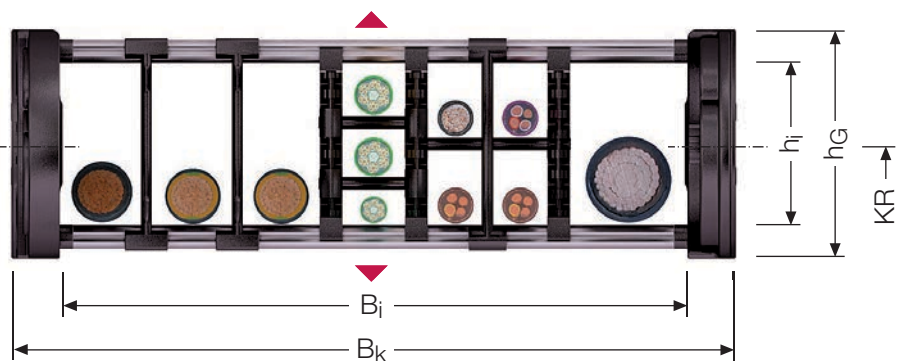

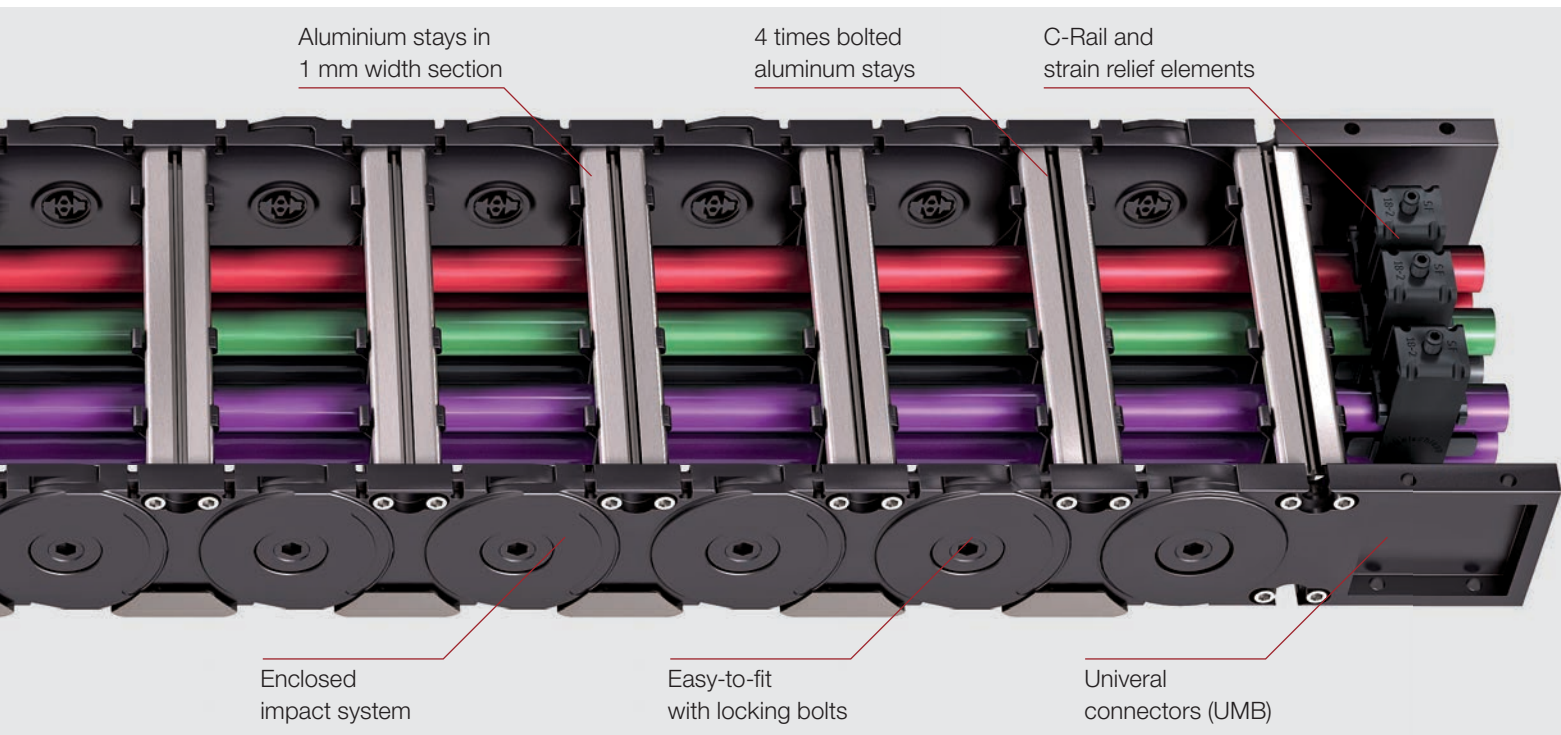

Type	Stay variant	Pitch t	h _i	h _G	B _i	B _k	Bend radius KR						
							140	170	200	260	290	320	380
MC 0950	RS	95	58	80	100 – 400	B _i + 39	140	170	200	260	290	320	380
	RM		54		100 – 600								
MC 1300	RMF	130	87	120	100 – 800	B _i + 50	240	320	360	500			

Dimensions in mm / Weights in kg/m

Aluminum stay RS

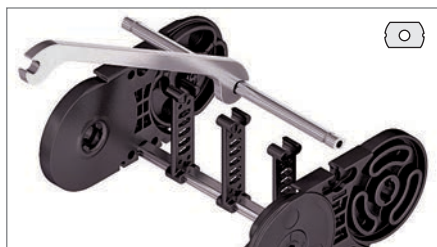

Frame stay standard design

Aluminum profile bars for lightweight to medium loads. Assembly without screws. Customized available in **1 mm width sections**.

Outside/Inside: can be opened quickly by rotating the stays through 90°.

Aluminum stay RM

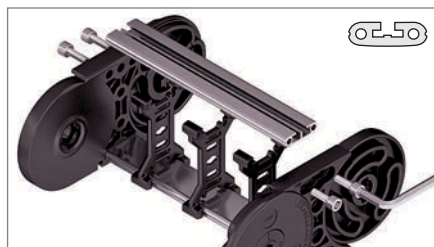

Frame stay solid design

Aluminum profile bars for maximum loads and maximum chain widths. Double-sided double screw connection. Customized available in **1 mm width sections**.

Outside/Inside: can be opened quickly by loosen the screws.

Aluminum stay RMF

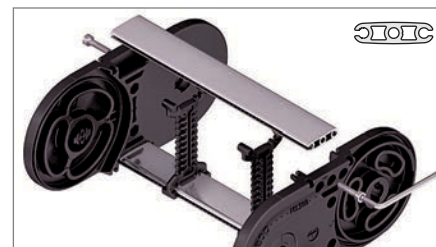

Frame stay solid design

Aluminum profile bars with optional fixing strip for maximum loads and maximum chain widths. Easily screwed on. Customized available in **1 mm width sections**.

Outside/Inside: can be opened quickly by loosen the screws.

Gliding arrangement: A cost-effective solution for your application

Single-Sided Gliding Arrangement:

Here, the upper run of the cable and hose carrier glides on the lower run and/or on the support element of the guide channel. The single-sided arrangement is the most common and cost-effective solution.

TSUBAKI KABELSCHLEPP supplies the cable carrier, guide channel, cables and hoses, and strain relief devices – the complete system solution. Cable carriers in this configuration operate trouble-free in installations all over the world.

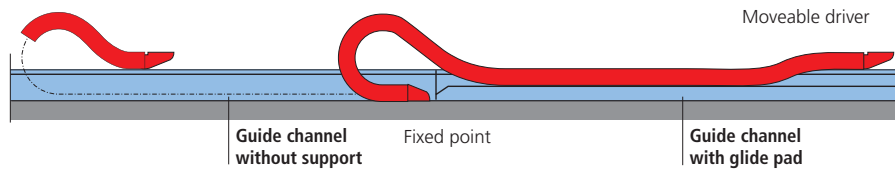

One-sided arrangement

Opposed Two-Sided Gliding Arrangement:

With high additional loads, the cables in an Opposed Arrangement can be distributed between two opposing

cable carriers. This allows the installation width to be reduced and the separation of power, control and signal cables is also possible.

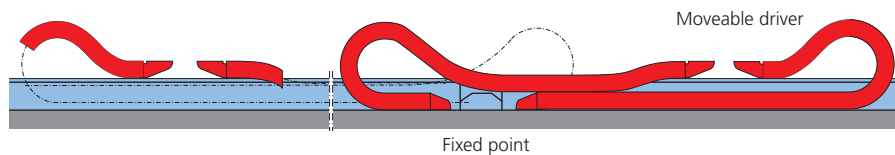

Opposing arrangement



Replaceable OFFROAD glide shoes – the cost-effective solution

OFFROAD glide shoes increase the lifespan of cable carriers running in gliding arrangements where the gliding surface of the cable carrier is exposed to heavy loads. In case of wear, simply replace the glide shoes instead of the entire cable carrier. Our glide shoes reduce costs and standstill times. They are made from highly abrasion-resistant material, and have 80 % more wearing volume than our standard glide shoes.

- increased lifespan of cable carrier
- reduced costs and standstill times
- only the glide shoes instead of the complete carrier needs to be replaced
- 80 % more wearing volume
- made of a special, highly abrasion-resistant material with low friction coefficients

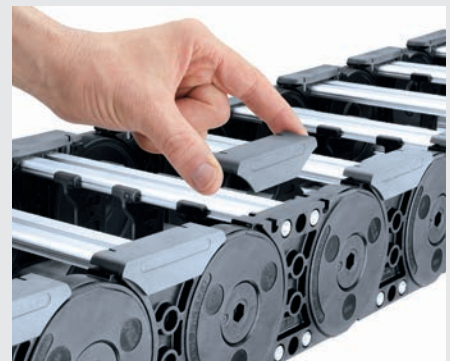

Minimized hinge wear owing to the “life extending 2 disc principle“

In the M Series, the push and pull forces are transmitted via the optimum link design for this purpose. As a result link wear is reduced to a minimum and the life of the cable carrier is considerably lengthened.

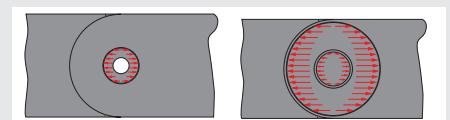

Force transmission with a pin-hole joint

Force transmission with the “life extending 2 disc principle“

TK System Channel: Easy to assemble and low maintenance times

The TK System Channel is especially designed for cranes and long travel applications.

The cable carrier is guided in the channel during travel. Lateral slippage of the upper run from the lower run is thus reliably prevented.

The structure of the system channel is designed for easy and time-saving assembly and disassembly. To minimize downtimes, individual channel elements can be disassembled for maintenance purposes.

Depending on the installation situation, the system channel is equipped with integrated slide rails which support the upper run of the cable carrier.

The open construction ensures that dirt and debris simply fall through the channel. The construction avoids system downtimes caused by accumulated dirt that impairs the operation of the cable carrier.

For a quick and easy on-site-installation the TK System Channel is delivered pre-assembled including the side elements and holders.

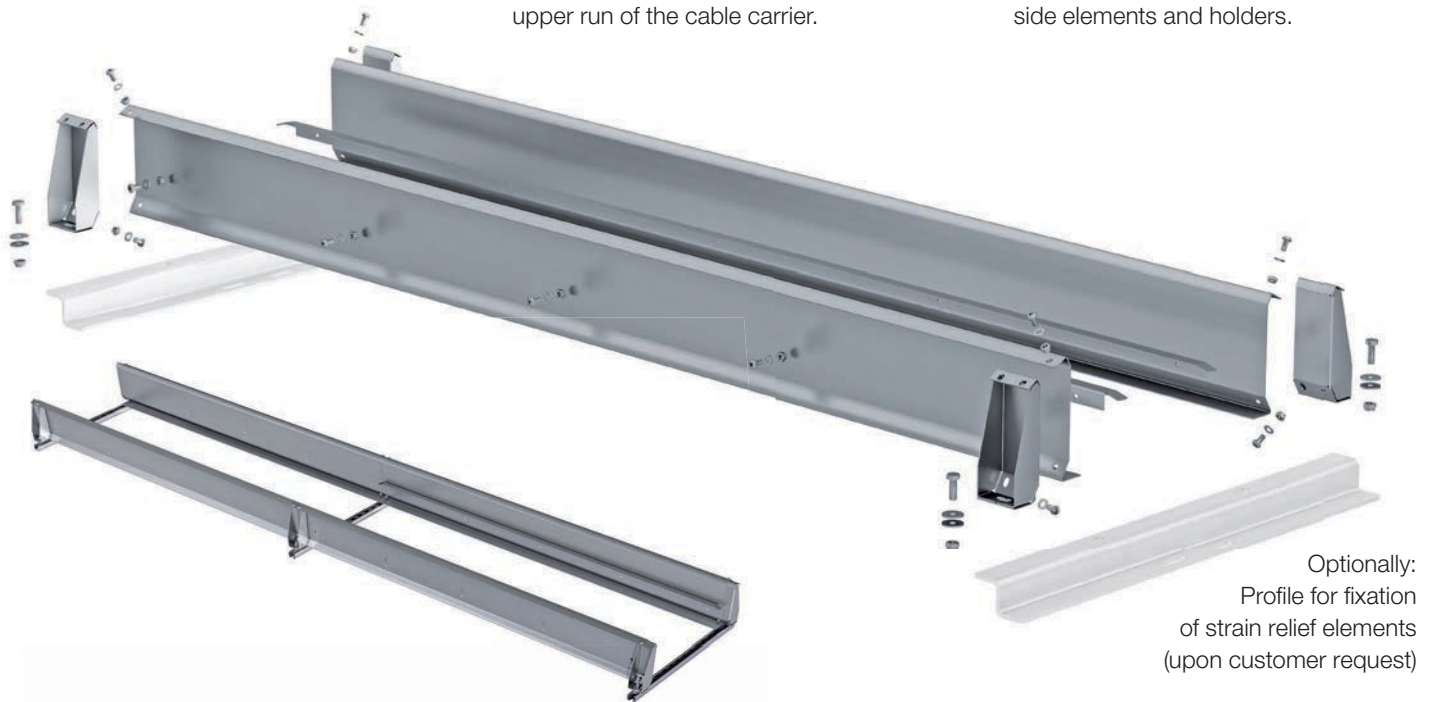

Optionally:
Profile for fixation
of strain relief elements
(upon customer request)

Protection against external influences: Maintenance-friendly housing

The housing protects the cable carrier and the cables against external influences and can be used in combination with the channel system.

The housing can be opened without tools in any position for inspection and maintenance of the cable carrier.





TRAXLINE® Cables – developed for cranes

The TSUBAKI KABELSCHLEPP family of continuous-flex cables has been specially developed for optimal use in dynamic cable and hose carriers.

TSUBAKI KABELSCHLEPP cables are distinguished by high reliability and performance at low costs, as well as by a long service life even in outdoor long term use. Crane applications with long travel paths and high travel speeds place high demands on electrical cables.

The Series 700 is optimized for outdoor use, e.g. on container cranes, due to the use of high quality, UV & ozone resistant materials and the special design.

**Permanently flexible
from – 40 °C to + 90 °C**

The highly flexible and cold-resisting single-core cables of the **POWER ONE 700 series** were designed specifically for permanently low temperatures down to

– 40 °C. They are manufactured with sophisticated extrusion technology and have excellent unwinding smoothness.

Any occurring system vibrations caused by changes in acceleration of the cable carrier are significantly reduced, which prolongs the service life.

High-Flex Cables – 700 series

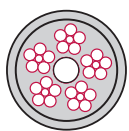

**Core insulation
KS-PP**
bundled stranding
(> 8 cores)

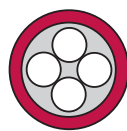

**Outer jacket
KS-PUR**
pressure extruded, hi-flex
design, extremely
abrasion-resistant

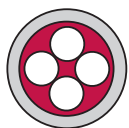

**Inner jacket
KS-TPE**
valley-sealed, pressure
extruded, hi-flex design

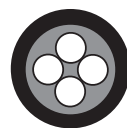

**Jacket colour
black**
ozone-resistant
UV-resistant

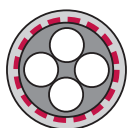

Overall shield
continuous bending hi-flex,
tin-plated copper braiding
for smallest bend radii

Developed for

- long travel length crane applications
- – 40 to + 90 °C
- outdoor / indoor
- offshore / onshore
- very high electrical voltages
- small bend radii
- high speed (up to 50 m/s)
- high acceleration (up to 50 m/s²)

Properties

- high flex design
- side pressure strength
- seawater-resistant
- ozone-resistant
- UV-stable
- crude oil resistant
- flame-retardant
- cut resistant
- halogen-free
- silicone-free
- CFC-free
- RoHS II conform
- metermarked
- MUD resistance



TRAXLINE® CONTROL 700 0.6 kV

Unshielded continuous bending hi-flex
PUR control cables

Temperature range fix:	- 50 to + 90 °C
Temperature range in motion:	- 30 to + 90 °C
Minimum bend radius moved:	$KR_{min} \geq 7.5 \times \varnothing$
$v_{max} a_{max}$:	20 m/s 50 m/s ²
Wire cross section:	0.5 ² to 1 ²
Core number:	2 – 49
Cable diameter:	5.8 – 21.3 mm



TRAXLINE® POWER 700 1 kV

Unshielded continuous bending hi-flex
PUR power cables

Temperature range fix:	- 50 to + 90 °C
Temperature range in motion:	- 30 to + 90 °C
Minimum bend radius moved:	$KR_{min} \geq 7.5 \times \varnothing$
$v_{max} a_{max}$:	20 m/s 50 m/s ²
Wire cross section:	1.5 ² to 95 ²
Core number:	2 – 36
Cable diameter:	7.5 – 45.1 mm



TRAXLINE® POWER ONE 700 PE

Unshielded continuous bending hi-flex
PUR single-core cables with PE core identification

Temperature range fix:	- 50 to + 90 °C
Temperature range in motion:	- 40 to + 90 °C
Minimum bend radius moved:	$KR_{min} \geq 7.5 \times \varnothing$
$v_{max} a_{max}$:	20 m/s 50 m/s ²
Wire cross section:	1.5 ² to 240 ²
Core number:	1
Cable diameter:	5.4 – 30.2 mm



TRAXLINE® POWER ONE 700 C 1 kV

Shielded continuous bending hi-flex
PUR single-core cables

Temperature range fix:	- 50 to + 90 °C
Temperature range in motion:	- 40 to + 90 °C
Minimum bend radius moved:	$KR_{min} \geq 7.5 \times \varnothing$
$v_{max} a_{max}$:	20 m/s 50 m/s ²
Wire cross section:	1.5 ² to 300 ²
Core number:	1
Cable diameter:	6.4 – 35.4 mm



TRAXLINE® FOC 700

Continuous bending hi-flex
multi-mode glass fiber optic cables

Temperature range fix:	- 50 to + 90 °C
Temperature range in motion:	- 30 to + 90 °C
Minimum bend radius moved:	$KR_{min} \geq 7.5 \times \varnothing$
$v_{max} a_{max}$:	3.5 m/s 10 m/s ²
Wire cross section:	50 μ / 62.5 μ
Core number:	6 – 12
Cable diameter:	13.4 mm



TRAXLINE® CONTROL 700 C 0.6 kV

Shielded continuous bending hi-flex
PUR control cables

Temperature range fix:	- 50 to + 90 °C
Temperature range in motion:	- 30 to + 90 °C
Minimum bend radius moved:	$KR_{min} \geq 7.5 \times \varnothing$
$v_{max} a_{max}$:	20 m/s 50 m/s ²
Wire cross section:	0.5 ² to 1 ²
Core number:	3 – 49
Cable diameter:	7.1 – 30.0 mm



TRAXLINE® POWER ONE 700 1 kV

Unshielded continuous bending hi-flex
PUR single-core cables

Temperature range fix:	- 50 to + 90 °C
Temperature range in motion:	- 40 to + 90 °C
Minimum bend radius moved:	$KR_{min} \geq 7.5 \times \varnothing$
$v_{max} a_{max}$:	20 m/s 50 m/s ²
Wire cross section:	0.25 ² to 700 ²
Core number:	1
Cable diameter:	4.1 – 49.9 mm



TRAXLINE® POWER 700 C 1 kV

Shielded continuous bending hi-flex
PUR power cables

Temperature range fix:	- 50 to + 90 °C
Temperature range in motion:	- 30 to + 90 °C
Minimum bend radius moved:	$KR_{min} \geq 7.5 \times \varnothing$
$v_{max} a_{max}$:	20 m/s 50 m/s ²
Wire cross section:	1.5 ² to 150 ²
Core number:	2 – 49
Cable diameter:	9.1 – 62.5 mm



TRAXLINE® POWER ONE HEAVY DUTY 10–30 kV

Shielded continuous bending hi-flex
PUR high performance cables

Temperature range fix:	- 50 to + 90 °C
Temperature range in motion:	- 40 to + 80 °C
Minimum bend radius moved:	$KR_{min} \geq 7.5 \times \varnothing$
$v_{max} a_{max}$:	50 m/s 50 m/s ²
Wire cross section:	10 ² to 400 ²
Core number:	1
Cable diameter:	21.5 – 65.5 mm

TRAXLINE® pre-assembled

You need connection-ready harnessed
cables and cable carrier systems?
Simply order in one step.



KABELSCHLEPP

The TSUBAKI KABELSCHLEPP Global network – worldwide near you



Information also on your Smartphone!
(QR READER app is a free of charge download)

kabelschlepp.de/global-crane-network

U.S. TSUBAKI KABELSCHLEPP
7100 W. Marcia Rd.
Milwaukee, WI 53223
Phone: 414.354.1994
www.ustsubaki.com

TSUBAKI KABELSCHLEPP worldwide
For contacts, addresses and
much more, visit our web site at
kabelschlepp.de