

## U.S. Tsubaki AS Series

### ENTER THE “KEYLESS” SOCIETY

Our POWER-LOCK® solves your problems.

Eliminate backlash damage to keyways from heavy loads... the U.S. Tsubaki POWER-LOCK fits tightly around the shaft/hub and is not affected by load reversals.

End your high machining expenses for long shaft keyways, splined shafts, threads, grooves and steps... the U.S. Tsubaki POWER-LOCK offers exacting, slip-free location.

Erase the headaches of shrink and press fits. The U.S. Tsubaki POWER-LOCK simplifies installation and removal.

This easy-to-install unit slides into position and offers a keyless shaft-hub lock that will simultaneously handle both high torque and thrust while increasing your shaft strength.

The POWER-LOCK is easy to assemble... you only need one tool. It is ideal for locking in large or small sprockets, gears, pulleys, timing cams and rollers. Best of all, the POWER-LOCK is in stock for immediate shipment.

### Features & Applications

#### ■ High Durability Against Reversing or Impacting Loads

The POWER-LOCK connection is not affected by torsional load reversal or impact, which damages the key and keyway connection. U.S. Tsubaki POWER-LOCK fits tightly around the shaft/hub and is free of backlash.

#### ■ Easy and Precise Positioning

The POWER-LOCK offers 360-degree angular adjustment and is excellent for indexing tables, cam mechanisms, gear drives and double-strand conveyor sprockets.

#### ■ Thrust Capability

The U.S. Tsubaki POWER-LOCK can hold axial forces, too. Typical applications with these forces include indexing tables and bevel gears.

#### ■ Easy Assembly and Disassembly

The POWER-LOCK can be assembled and disassembled frequently, so maintenance or replacement of worn parts is simple and easy as compared to other methods (key and keyway, spline, shrink or press fits and welding).

#### ■ Increased Shaft Strength

By using the POWER-LOCK, no metal needs to be removed from the shaft (such as the cutting of a keyway). The strength of the shaft can be kept at its original diameter. This savings can be especially noted on hollow-shaft applications.

#### ■ Eliminates Costly Machining

There is no need for time-consuming machining of keyways. The POWER-LOCK offers substantial savings on long, heavy shafts.



U.S. Tsubaki POWER-LOCK® Offers a

# POWER-LOCK®

## Construction



The POWER-LOCK® is composed of five parts: taper ring (A), taper ring (B), outer ring, inner ring, and locking bolts. Locking is achieved by tightening the bolts.

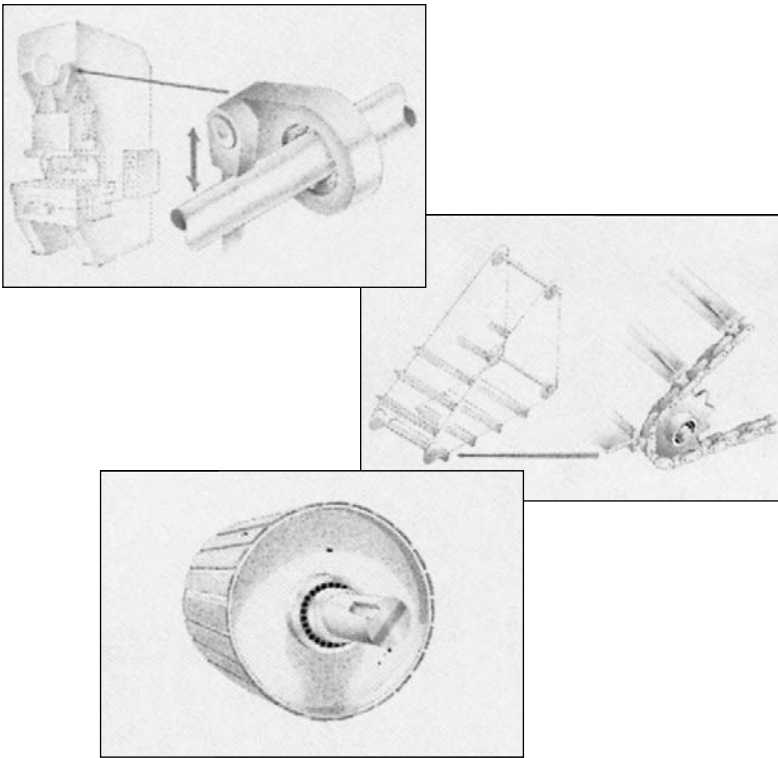
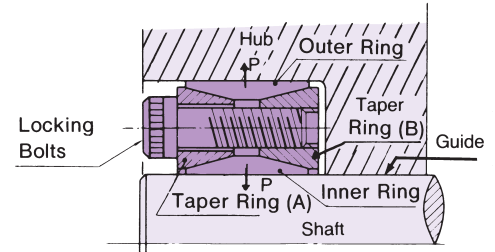

## Connecting Principle

Taper rings (A) and (B) fit perfectly with the tapered inner and outer rings. By tightening the locking bolts, taper rings (A) and (B) generate clamping pressure ( $P'$  and  $P$ ) against the outer and inner rings to produce the frictional force to join the shaft and hub. A slit is provided on the circumference of the outer and inner rings to secure the clamping force.

**Whole New Approach to Replacing Keyways**