

DIMENSION DIAGRAM (3)

Free Input R-type Reducer (1/4 H.P. to 30 H.P.) (Speed Reduction Ratio 2.5:1 and 5:1)

Example of model number

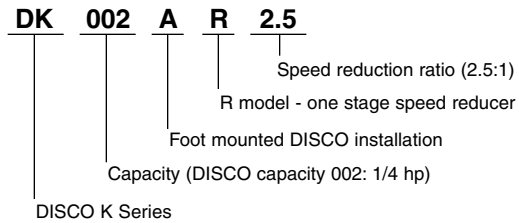

DK002AR2.5
DK002AR5

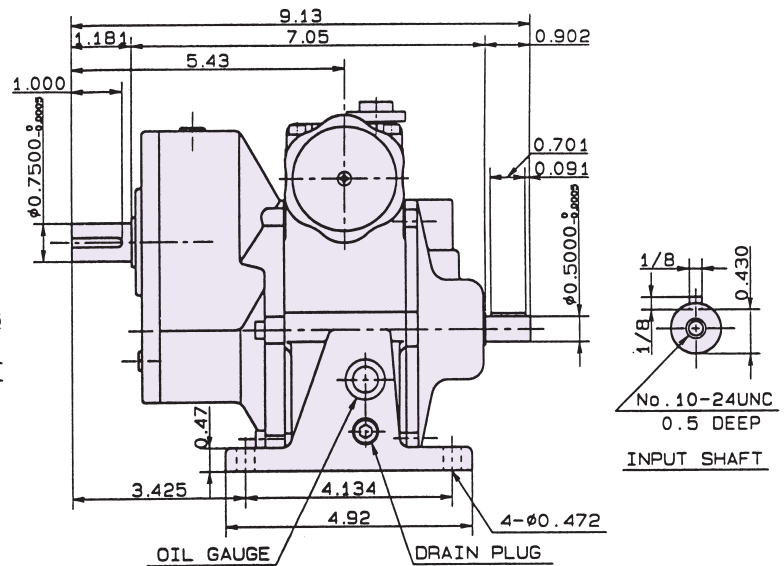
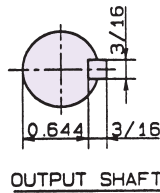
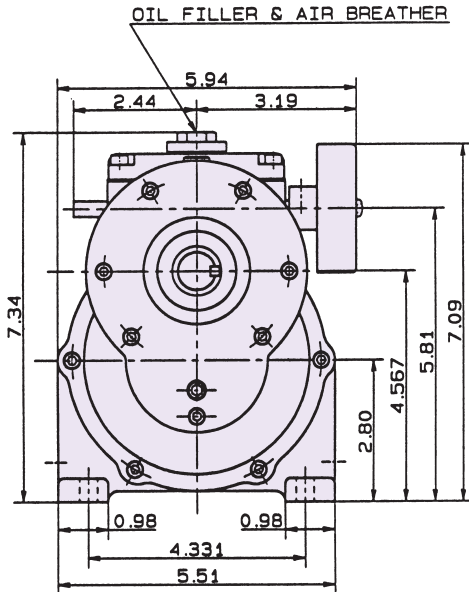

Weight: 30 lbs.

DK004AR2.5
DK004AR5

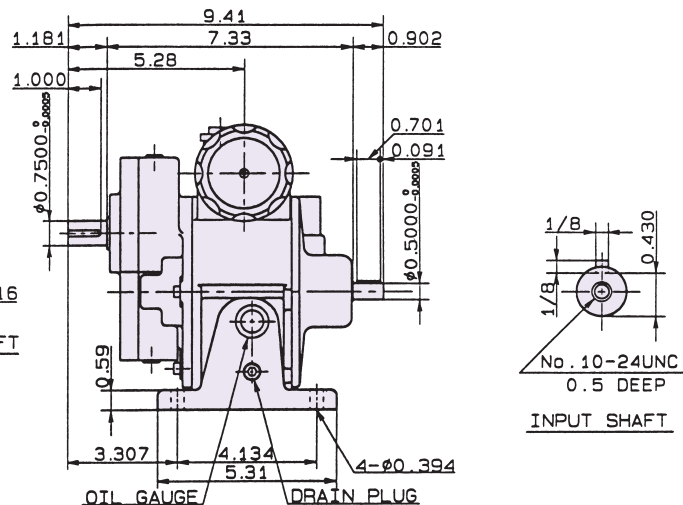
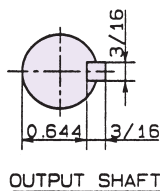
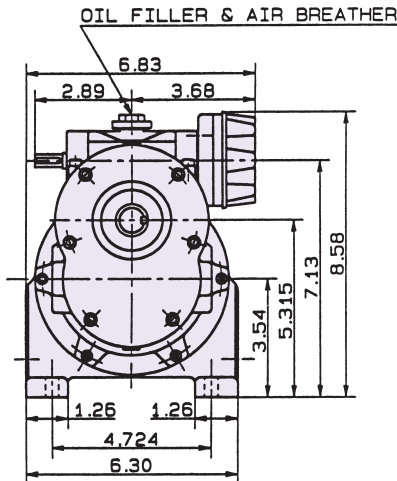

Weight: 37 lbs.

DK007AR2.5
DK007AR5

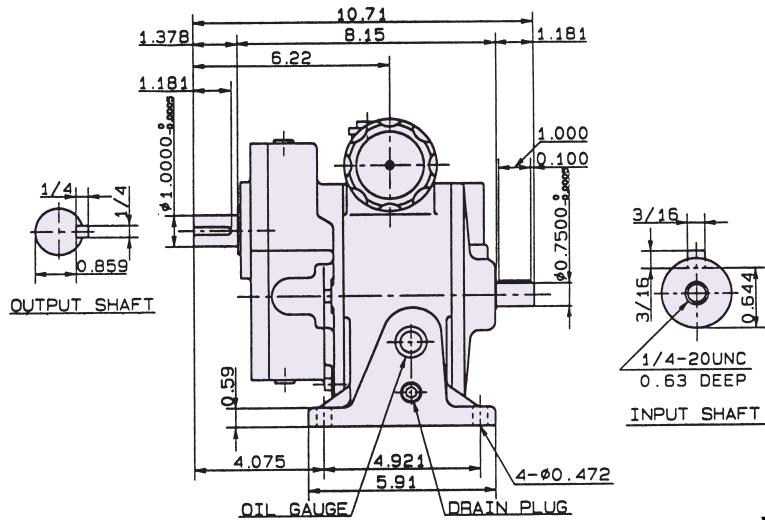
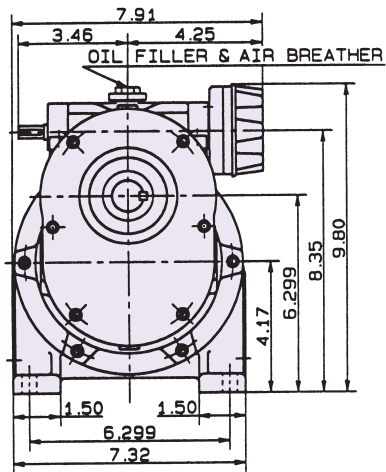

Weight: 53 lbs.

DK015AR2.5
DK015AR5

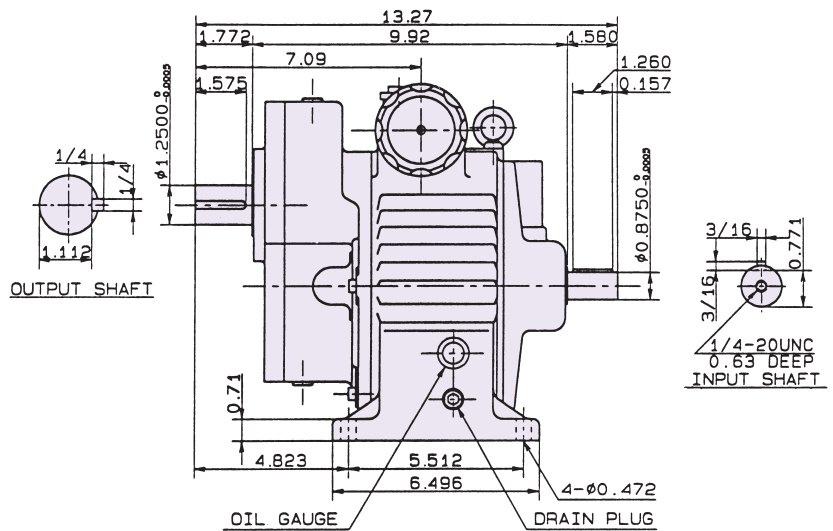
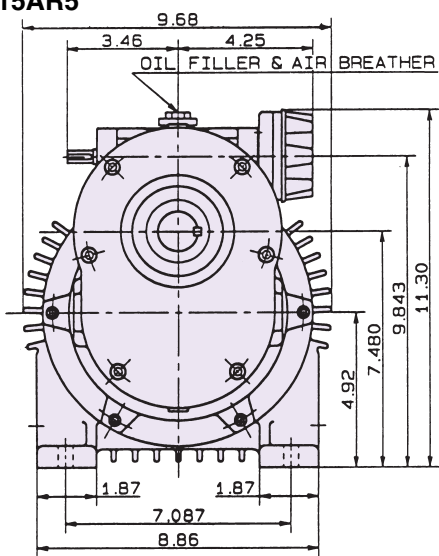

Weight: 89 lbs.

DK022AR2.5
DK022AR5

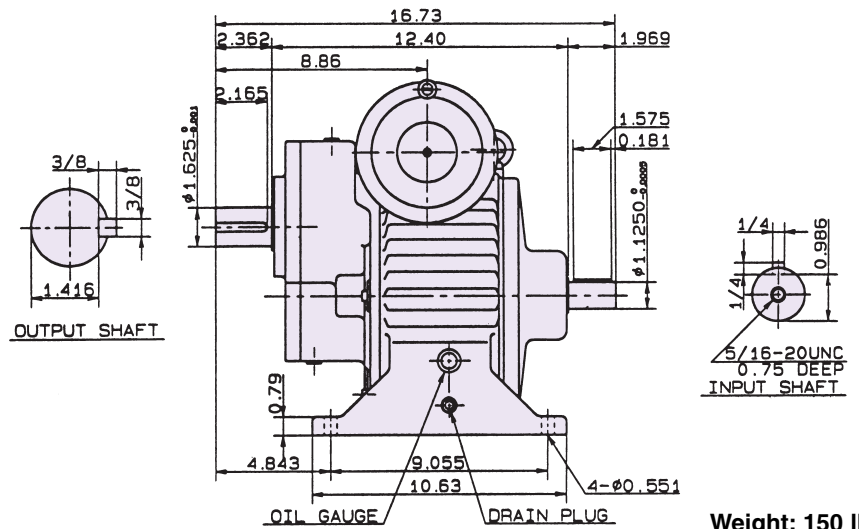
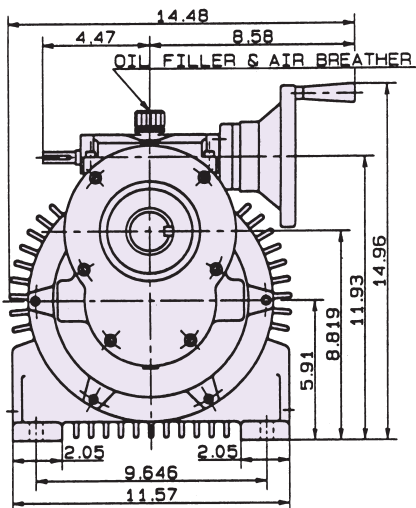

Weight: 150 lbs.

U.S. TSUBAKI DISCO

DK037AR2.5
DK037AR5

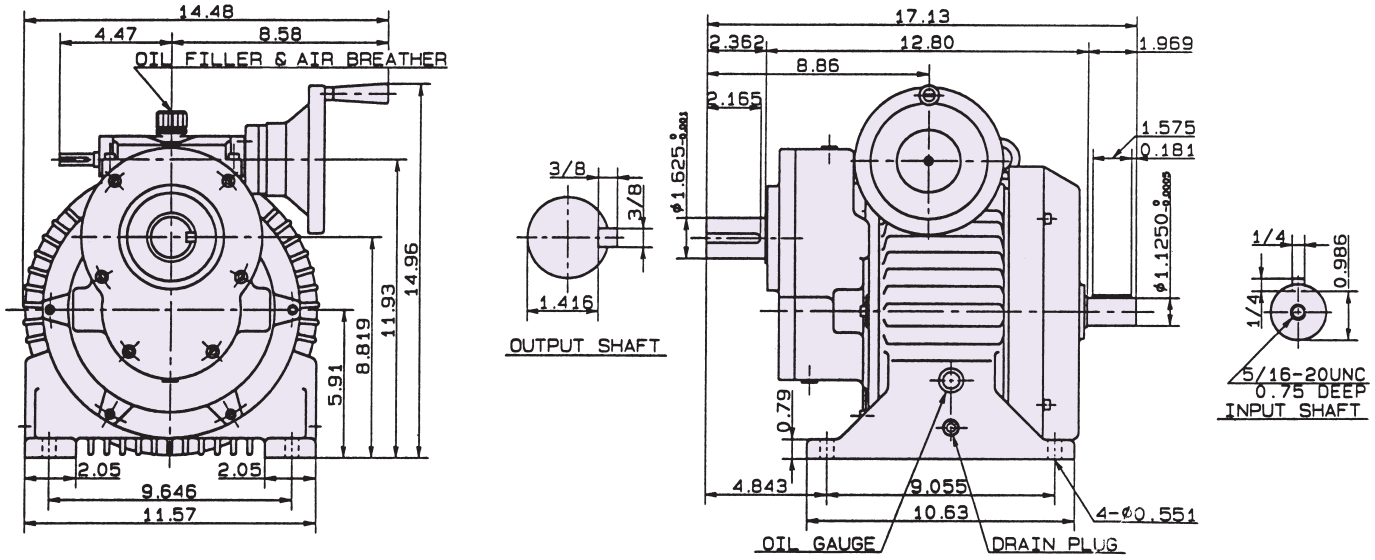

Weight: 160 lbs.

DK055AR2.5
DK055AR5
DK075AR2.5
DK075AR5

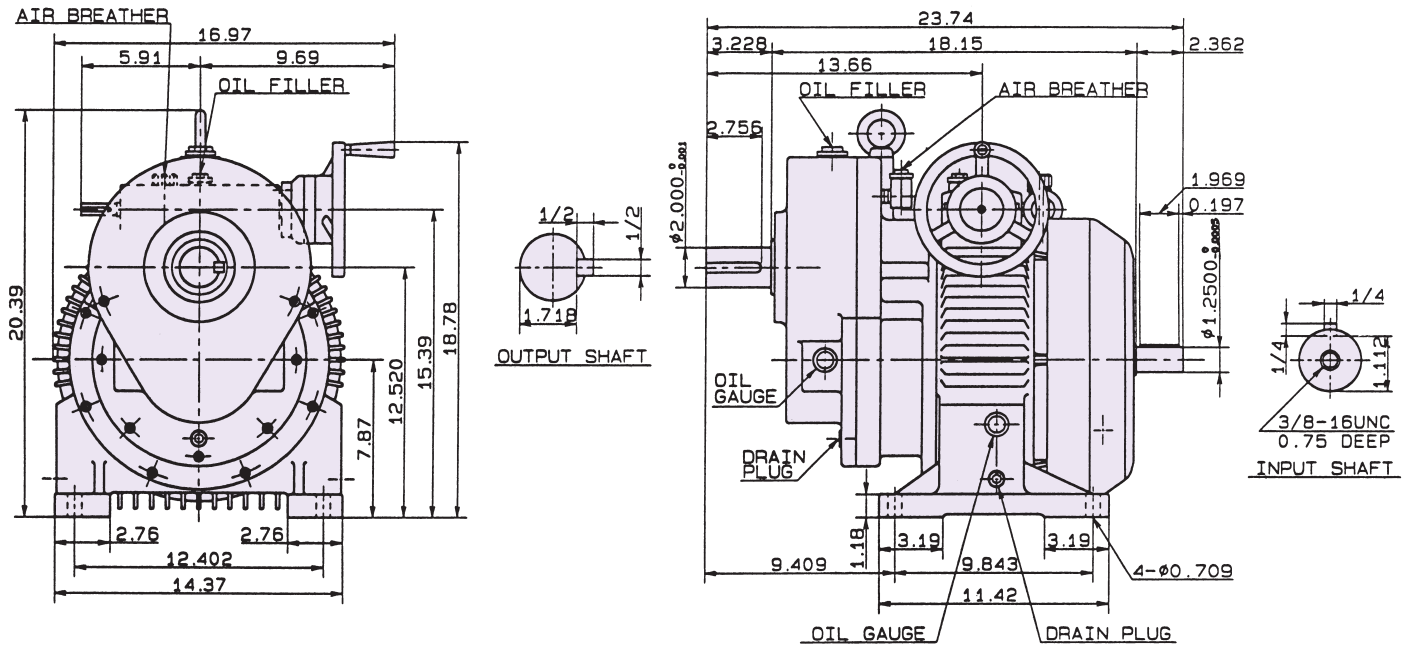

Weight: 418 lbs.